

Dump Valves DVU Series

The DVU Series features pneumatically controlled dump valves. The valves open and close automatically by pneumatic control from FW Murphy level controller and dump valve operator. Diaphragm actuated, the DVU series dump valves operate at 30–70 psi (207–483 kPa) [2.07–4.83 bar] and up to 2000 psi (13.8 MPa) [138 bar] vessel pressure (depending on the model).

A key benefit of this design is a hex union that provides the ability to replace the seat without removing the valve from piping.

The DVU Series is compatible with FW Murphy level controllers. They feature a soft seat valve and manual valve operator.

Designed for gas compressor scrubbers, the DVU Series can be used to dump any liquids compatible with its materials of construction.

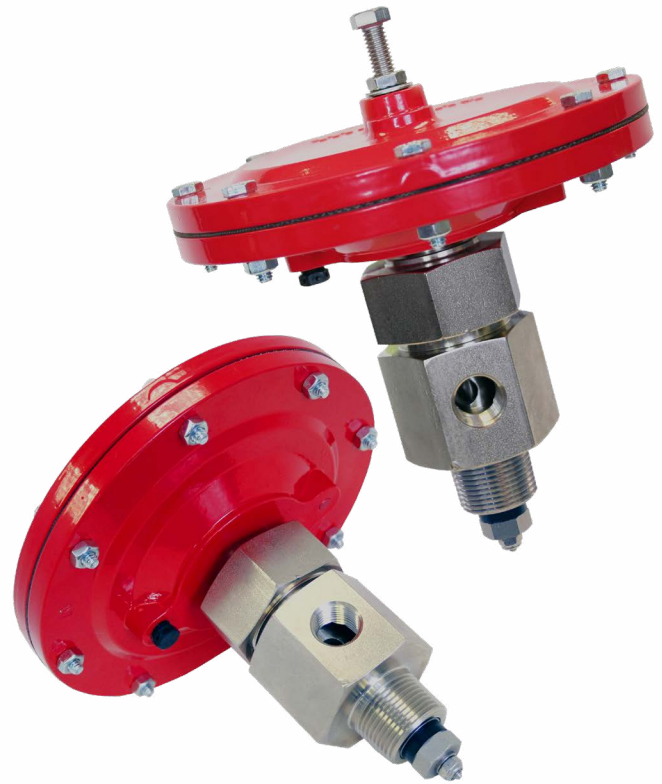

Dimensions

DVU 150 and 175

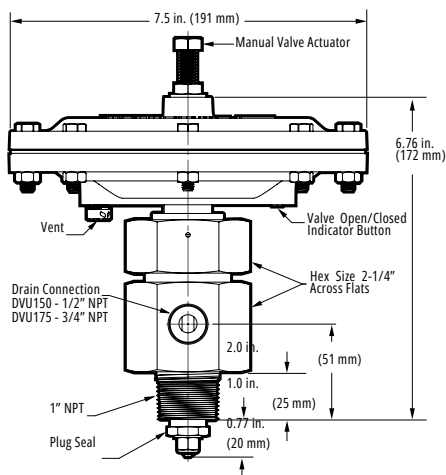

DVU 2105, 2115 and 2120

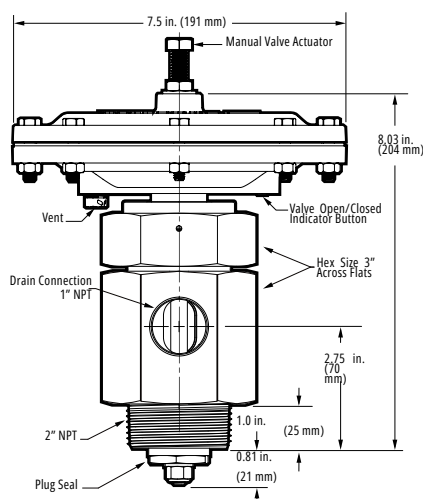

Specifications

Operating Temperature: -30° to 250°F (-34.4° to +121°C)

Valve Operating Pressure: See How to Order

Maximum Working Pressure:

DVU150/175 (STD & SS): 1800 psi (12.4 MPa) [124 bar]

DVU2105: 500 psi (3.44 MPa) [34 bar]

DVU2115: 1500 psi (10.3 MPa) [103 bar]

DVU2120: 2000 psi (13.8 MPa) [138 bar]

Wetted Parts

Standard Models:

Body/Union Nut: 12L14 carbon steel, electroless nickel-plated

Stem: ANSI 303 SS

Stuffing Box: ANSI 303 SS

Seat: ANSI 303 SS

Plug/Seal: ANSI 303 SS / 95 durometer urethane

Stainless Steel Models:

Body/Union Nut: ANSI 316 SS

Stem: ANSI 316 SS

Stuffing Box: ANSI 316 SS

Seat: ANSI 316 SS

Plug/Seal: ANSI 316 SS / 95 durometer urethane

Scrubber Level Systems (SLS)

The FW Murphy Gas Compressor Scrubber Level System (SLS)

The system provides for liquid control in gas scrubber applications, by dumping liquids to drain and protecting compressors with a high liquid level switch. Wetted metal parts are made to survive constant use in corrosive environments.

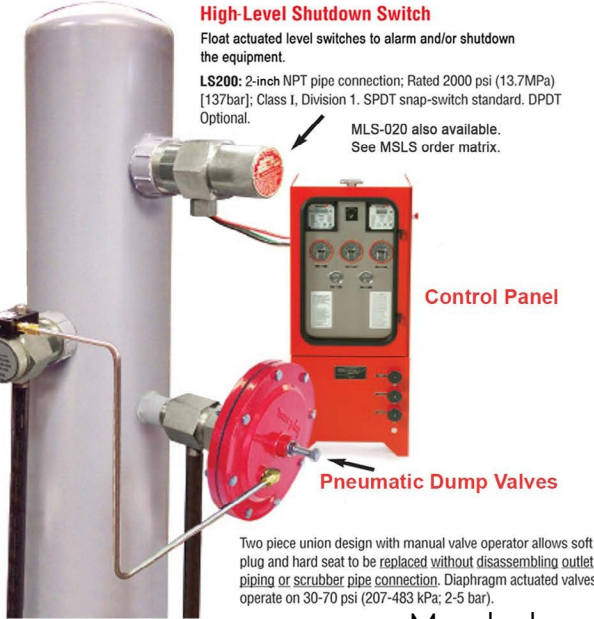

Pneumatic Level Control
Float actuated level snap-acting switch controls pneumatic pressure to open and close dump valve.
LS200NDVOR: Dump Valve Operator, pressure regulator and pressure indicating Gage.

SLS includes LS200, LS200NDVOR and DVU valve:

- SLS2120** - Includes DVU2120 valve
- SLS150** - Includes DVU150 valve
- LR** - Less regulator option available

MSLS includes MLS-020, LS200NDVOR and DVU valve:

- MSLS150** - Includes DVU150 valve
- LR** - Less regulator option available
- TF** - Test function option available with MSLS150

How to Order

Part Number	Model and Description	Notes
Use Model Number	DVU2120	
	DVU2115	
	DVU2105	
	DVU175	
	DVU175SS	
	DVU150	
	DVU150SS	
	55000272	DVU2120 Seal Kit
55000273	DVU2120 Diaphragm Kit	
55000271	DVU2115 Seal Kit	
55000273	DVU2115 Diaphragm Kit	
55000270	DVU2105 Seal Kit	
55000273	DVU2105 Diaphragm Kit	
55000230	DVU150/175 Seal Kit	
55000231	DVU150/175 Diaphragm Kit	
55000255	DVU150/175 End Seal Kit	
55000262	DVU150SS/175SS Seal Kit	
55000231	DVU150SS/175SS Diaphragm Kit	

Models

Model	Inlet	Outlet	Trim Size inches (mm)	Working Max. Press.
DVU2120	2 NPT	1 NPT 1	0.500 (12.7)	2000 psi
DVU2115	2 NPT	NPT 1	0.571 (14.5)	1500 psi
DVU2105	2 NPT	NPT 3/4	0.791 (20.09)	500 psi
DVU175	1 NPT	NPT 3/4	0.359 (9)	1800 psi
DVU175SS	1 NPT	NPT 1/2	0.359 (9)	1800 psi
DVU150	1 NPT	NPT 1/2	0.359 (9)	1800 psi
DVU150SS	1 NPT	NPT	0.359 (9)	1800 psi

Pressure vs. Flow (DVU150/175)

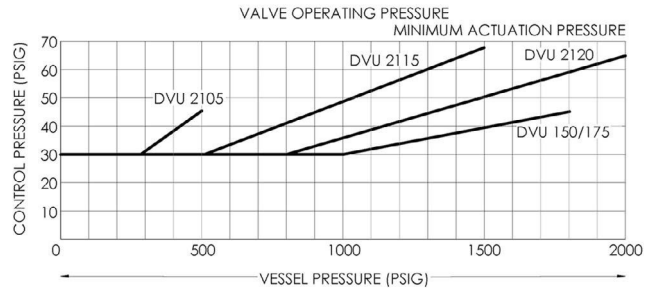
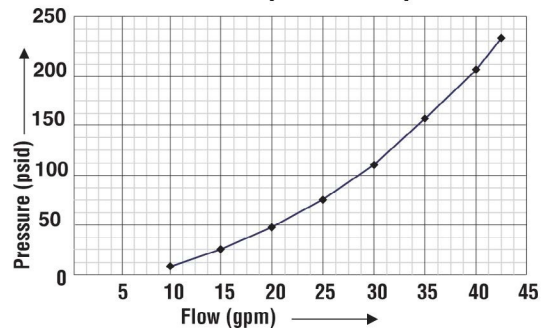

Approximate Shipping Weight and Dimensions		
Model	Weight	Dimension
DVU150, DVU150SS, DVU175, DVU175SS,	9 lbs. (4 kg)	8 x 8 x 12 in. (203 x 203 x 305 mm)
DVU2105, DVU2115, DVU2120	14 lbs. (6.4 kg)	



CONTACT
 sales@rajkotmarinellc.ae
 +971 6 7487580
 www.rajkotmarine.com

RAJKOT MARINE LLC
 Jurf Industrial Area 1,
 P.O Box 5861
 Ajman, UAE

